

Marvell 88DE3100 High-Definition Secure Media Processor System-on-Chip (SoC)



▶ PRODUCT OVERVIEW

The Marvell® ARMADA™ 1500 (88DE3100) secure media processor system-on-chip (SoC) is a high-definition (HD) advanced multi-format video and audio decoder that includes two high-performance ARMv7 compatible PJ4B processors with symmetric multi-processing (SMP), a large L2 cache, and a complete set of peripherals. It decodes 2 full HD streams along with multi-channel audio and both 2D and 3D graphics pipelines that enable rich and sophisticated User Interfaces (UI) along with high performance gaming experience. It also provides support for the Blu-ray 3D specifications. The ARMADA 1500 has a dedicated secure processor that supports various DRM schemes and 4Kbit one-time-programmable memory and implements multiple crypto accelerators. Additionally, the ARMADA 1500 integrates a video/image post-processing subsystem that implements Marvell’s award-winning Qdeo™ processing, performing per-pixel 3D noise reduction, 3D de-interlacing, scaling, natural depth expansion, intelligent color remapping, and adaptive contrast enhancement. An integrated audio post-processor enables advanced audio algorithms such as Dolby®, DTS, and AEC for high-quality, multi-channel, and stereo audio output.

Marvell’s ARMADA 1500 provides a high-performance and cost-efficient solution for IP/cable/satellite set-top boxes (STBs), feature-rich connected Blu-ray players, digital media adapters (DMAs), Google TV™, and DTV applications with 88DE6010 (Marvell’s DTV analog front-end companion chip).

▶ BLOCK DIAGRAM

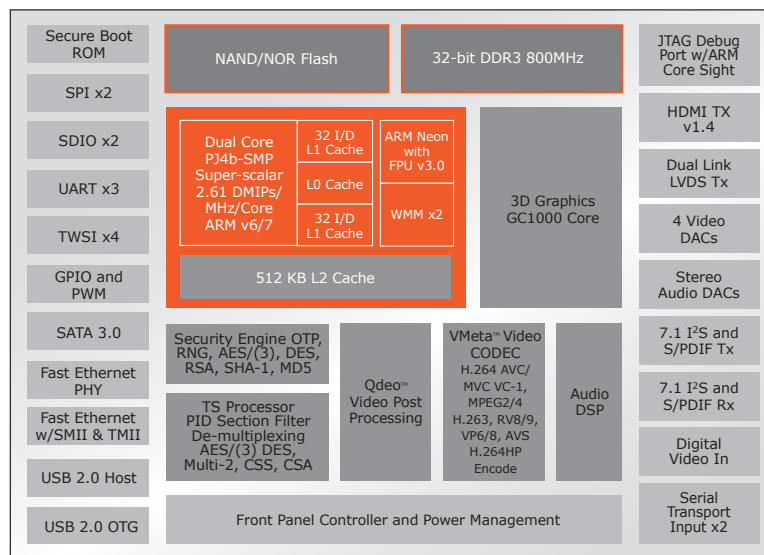

Fig 1. ARMADA 1500 (88DE3100) HD Media Processor SoC Block Diagram

▶ KEY FEATURES AND BENEFITS

FEATURES	BENEFITS
<ul style="list-style-type: none"> • Hardware-accelerated, dual-stream multi-standard, video decode and audio decode • Low-power SoC • Award-winning Qdeo video processing • Integrated Marvell dual-CPU SMP cores at 1.2 GHz 	<ul style="list-style-type: none"> • Multi-format AV decode support enables adoption in a number of different platforms and allows playability of a wide range of content • Low-power consumption enables fanless design • Delivers an immersive viewing experience • Dual cores running in Symmetric Multi-Processing configuration for quick startup and loading times, as well as uncompromised performance for many networked, Java, and Media applications
<ul style="list-style-type: none"> • Full suite of integrated peripherals (such as USB, Ethernet, HDMI, SATA, and SDIO) • Turnkey reference designs of connected applications 	<ul style="list-style-type: none"> • Allows for complete connectivity in DTV, BD, STB, and DMA applications. • Highly cost-effective products and fast time-to-market

Marvell 88DE3100 High-Definition Secure Media Processor System-on-Chip (SoC)

APPLICATIONS

Marvell provides a complete go-to-market solution for IP/cable/satellite/terrestrial DTV, STB, DMA, and Blu-ray products:

- High-performance HD media processor
- Optical front-end, HDMI input, component input, tuner/demod, and wifi receiver companion chips
- Comprehensive software development kit enables fast development and customization:
 - Both high-end Android-based and low-end Linux™-based solutions
 - Android™ SDK
 - Google TV
 - Both connected applications and base TV software stacks
 - DVD/VCD/CD-DA navigation
 - HDMV, BD-J stack
 - Ease of OSD customization

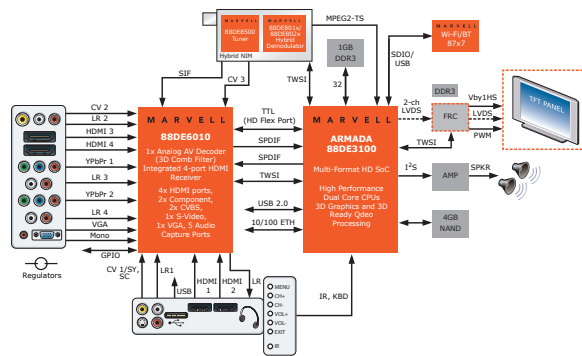

Fig 2. DTV System Diagram

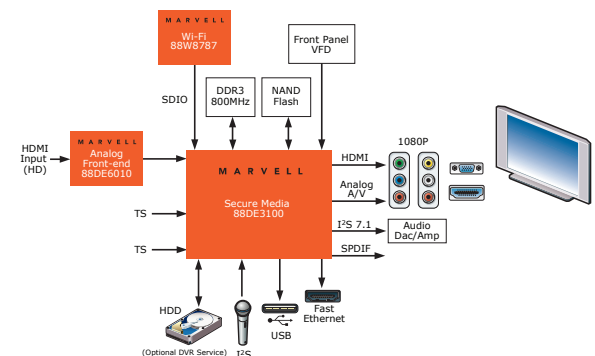

Fig 3. STB/DMA System Diagram

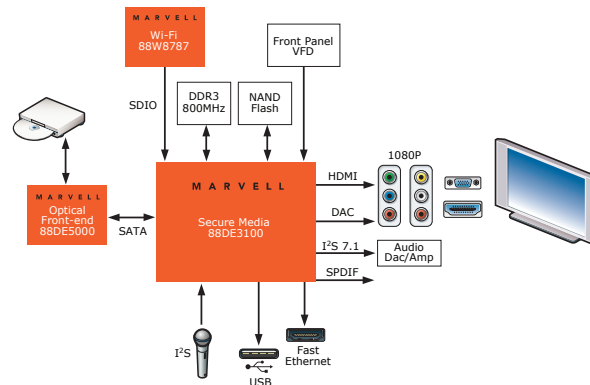

Fig 4. Blu-ray Player System Diagram

THE MARVELL ADVANTAGE: Marvell chipsets come with complete reference designs which include board layout designs, software, manufacturing diagnostic tools, documentation, and other items to assist customers with product evaluation and production. Marvell’s worldwide field application engineers collaborate closely with end customers to develop and deliver new leading-edge products for quick time-to-market. Marvell utilizes world-leading semiconductor foundry and packaging services to reliably deliver high-volume and low-cost total solutions.

ABOUT MARVELL: Marvell is a leader in storage, communications, and consumer silicon solutions. Marvell’s diverse product portfolio includes switching, transceiver, communications controller, processor, wireless, power management, and storage solutions that power the entire communications infrastructure, including enterprise, metro, home, storage, and digital entertainment solutions. For more information, visit our Web site at www.marvell.com.